

GRANITE

THE NO-NONSENSE ALL ROUNDER.

A tough, no-nonsense, workhorse. The Granite is all about getting the job done in heavy traffic, on open highways or around the toughest construction sites.

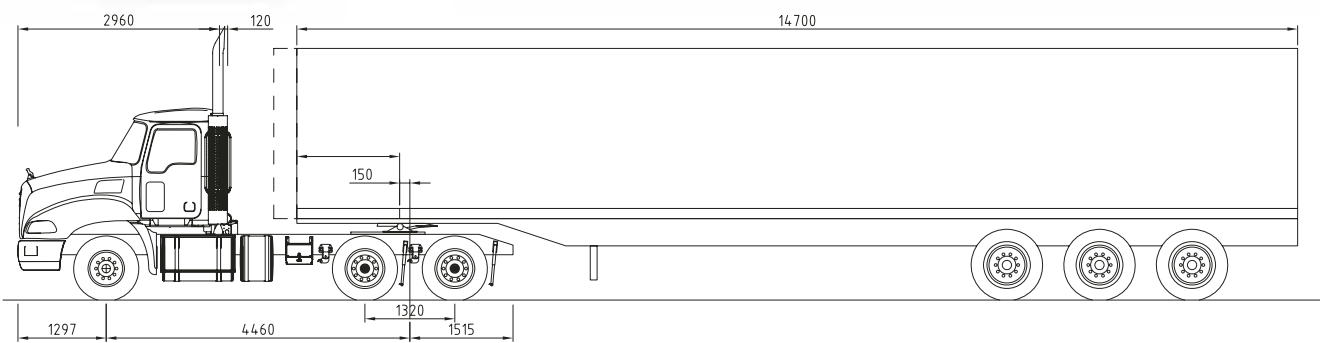

GRANITE 6X4 DAY CAB WITH 48" SEMI-TRAILER

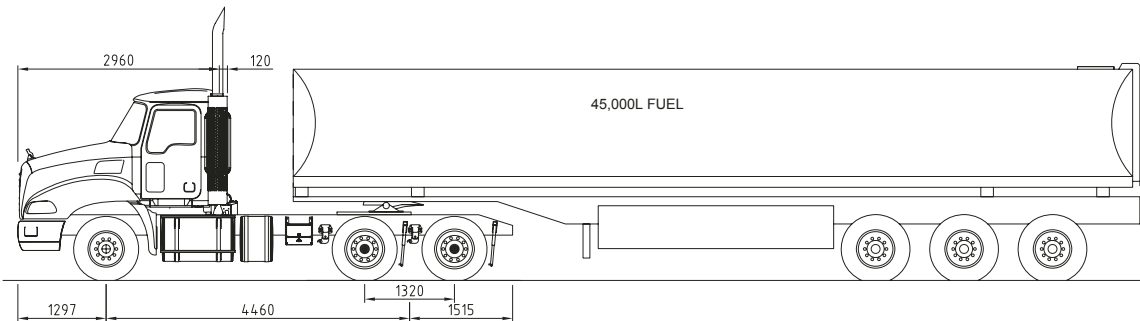

GRANITE 6X4 DAY CAB WITH FUEL TANKER

GRANITE WHEELBASE CHART

WHEELBASE* (WB)	EXHAUST TO CENTRE OF DRIVE (mm), CA**				MAXIMUM FUEL CAPACITY***	ADBLUE TANK CAP	TURNING CIRCLE (m)****
	Day Cab	Super Cab	40" Sleeper	46" Sleeper			
BBC							Kerb to Kerb
2960	2960	3570	3775	3930			
4460mm	2677				700L	125L	15.9
4660mm	2877	2387	2182		1000L	150L	16.5
4910mm	3127	2637	2432	2277	1000L	150L	17.3
5060mm	3277		2582	2427	1000L	150L	17.8
5210mm	3427			2577	1000L	150L	18.3
5510mm (Rigid Only)	3727				850L	125L	19.2
5810mm (Rigid Only)	4027				850L	125L	20.1
6110mm (Rigid Only)	4327				850L	125L	21.0

GVM: Up to 26,000kg[†] GCM: Up to 106 tonnes[†]

* Wheelbases calculated using 1320mm Bogie Spread.

** Distances shown are with rear exhausts Day Cab or forward mounted exhausts for sleeper.

*** Maximum fuel capacity is VSS selectable combinations with batteries mounted on chassis for day cab and inframe or in sleeper.

**** Turning circle measure to be used as a guide only. Refer to WIS.

† Subject to application.



MACKTRUCKS.COM.AU

Granite-D-08-2011 Printed in Australia

The information in this brochure was current at the time of publication. Mack Trucks reserves the right to make changes in specifications, equipment and design, or to discontinue models, options or extras without notice at any time. MACK and the Bulldog design are registered trademarks. All rights reserved. V-MAC is a registered trademark. All rights reserved.



GRANITE

DISTRIBUTION

ENGINE & TRANSMISSION					
ENGINE					
<div> <ul style="list-style-type: none">Mack MP8 12.8 litre Maxi-Cruise torque settings Selective Catalytic Reduction (SCR) Emission Level Euro5 (ADR80/03) </div>					
Horsepower (Hp)	435	500			
Torque (lb–ft)	1655	1840			
ENGINE BRAKE					
<div> <ul style="list-style-type: none">Powerleash engine brake Engine retarding power up to 315Kw (495hp) @ 2,100rpm </div>					
AIR INTAKE & FILTER					
<div> <ul style="list-style-type: none">Donaldson 279mm (11") Single dry type element Under bonnet air intake </div>					
FILTERS					
<div> <ul style="list-style-type: none">2 full flow and 1 bypass engine mounted oil filters 2 step dual engine mounted fuel filters/water separator </div>					
AIR COMPRESSOR					
<div> <ul style="list-style-type: none">2 CYL. 900 litres/min WABCO compressor </div>					
AIR DRYER					
<div> <ul style="list-style-type: none">Bendix AD-IS air dryer </div>					
ALTERNATOR					
<div> <ul style="list-style-type: none">Leece Neville 12volt/160Amp Brushless (standard) Leece Neville 12volt/185Amp Brushless (optional) </div>					
STARTER					
<div> <ul style="list-style-type: none">Delco Remy 39MTHD 12volt electric starter (standard) Key type start and stop </div>					

TRANSMISSION CHART						
MAKE	MODEL	MAX TORQUE CAPACITY	FWD GEARS	REV GEARS	LO/HI	TYPE
Mack	T310MLR	1,800ft–lbs	10	6	27.30/0.71	Manual
Mack	T318	1,800ft–lbs	18	3	13.44/0.71	Manual
Mack	T31821	2,100ft–lbs	18	3	13.44/0.71	Manual
Mack <i>m</i> DRIVE	<i>T</i> mD12AD (Direct)	1,920ft–lbs	12	2	14.94/1.0	Fully Automated
Fuller	RTLO16918	1,650ft–lbs	18	4	14.40/0.73	Manual
Fuller	RTLO18918	1,850ft–lbs	18	4	14.40/0.73	Manual
Fuller	RTLO20918	2,050ft–lbs	18	4	14.40/0.73	Manual

Note: RTLO16918 and MP8 435hp <50tonnes, RTLO18918 and MP8 500hp

AXLES & SUSPENSION					
FRONT AXLE					
<div> <ul style="list-style-type: none">Mack FXL with unitised hubs (Refer Steer Axle Chart) Axle position: Axle Back (AB) 1,297mm BFA </div>					
FRONT SUSPENSION					
<div> <ul style="list-style-type: none">1,321mm (52") long springs (Refer Steer Axle Chart) </div>					
FRONT BRAKES					
<div> <ul style="list-style-type: none">Front automatic slack adjusters Type 20 brake boosters Type 24 brake boosters S' Cam with iron drums (standard) S' Cam with centrifuse drums (optional) </div>					
STEERING GEAR					
<div> <ul style="list-style-type: none">Sheppard M100P Steering ratio 18.9:1 </div>					

FAN					
<div> <ul style="list-style-type: none">Behr Visco Drive (electric over viscous fan clutch) 750mm (29.5") 9-blade nylon fan </div>					
RADIATOR					
<div> <ul style="list-style-type: none">NL3, Frontal area 1,435in² </div>					
EXHAUST					
<div> <ul style="list-style-type: none">Single RHS frame mounted catalyst with stainless heat shield Outlet single RHS 152mm (6") vertical exhaust (Day Cab) Outlet twin 152mm (6") vertical exhaust (Day Cab) Outlet single LHS 152mm (6") vertical exhaust (Sleeper Cab) Outlet single 127mm (5") underframe outlet (optional) Exhaust tip height above ground 3.5mtr (standard) Exhaust tip height above ground 4.2mtr (optional) </div>					
TRANSMISSION					
<div> <ul style="list-style-type: none">Manual and Automated transmissions (Refer Transmission Chart) Transmission oil cooler (standard) </div>					
CLUTCH					
<div> <ul style="list-style-type: none">Eaton 394mm (15.5") Easy Pedal with VCT Plus (standard) Eaton ‘Solo’ with VCT Plus (optional) Single Plate 430mm (17") (standard with <i>m</i>DRIVE) Air assist clutch release (standard) </div>					
DRIVELINE					
<div> <ul style="list-style-type: none">Spicer 1810 Main shafts, 1710 Inter-axle 1810 interaxle and SPL driveline (NSV with <i>m</i>DRIVE only) </div>					
PTO OPTIONS					
<div> <ul style="list-style-type: none">Rear of engine PTO (REPTO) Transmission mounted PTO (optional on <i>m</i>DRIVE) Prep kit, switch and wiring only (optional) </div>					

AXLES & SUSPENSION (CONTINUED)					
INTER-AXLE/WHEEL LOCKS					
<div> <ul style="list-style-type: none">DCDL one axle only (vendor axles only) DCDL's on both axles (optional on Mack and vendor) Mack Power Divider (standard with Mack axles) </div>					
TYRES					
<div> <ul style="list-style-type: none">Michelin tyres as standard </div>					

STEER AXLE CHART					
MAKE	MODEL	CAPACITY	SUSPENSION*	COMMENTS	
Mack	FXL 14.6	14,600lbs (6.6t)	(P3, M7)	Standard axle	
Mack (Aus)	Twin FXL 14.6	29,200lbs (13t)	(P3)	Load share mechanical	
Mack (NZ)	Twin FXL 14.6	29,200lbs (13t)	(P3)	Non-load share mechanical	
Mack	FXL 18	18,000lbs (8.2t)	(H8)	For heavy duty applications	
Mack	FXL 20	20,000lbs (9.1t)	(P4, M8, H10)	For extra heavy duty applications	
Meritor	FG941 (NSV only)	14,600lbs (6.6t)	(P3, M7)	Disc brakes (NSV only)	

* Parabolic Standard Duty (P), Multileaf Standard Duty (M), Multileaf Heavy Duty (H) – Number = Leaf Qty

DRIVE AXLE CHART					
MAKE	MODEL	CAPACITY	RATIOS**	RATIOS (<i>m</i> DRIVE)	SUSPENSION
Mack	S440	44,000lbs (20t)	4.35, 4.73, 5.02 / 4.19, 4.50, 4.80	3.11, 3.25, 3.40	AL460
Mack	S462	46,000lbs (21t)	4.35, 4.73, 5.02 / 4.19, 4.50, 4.80	3.11, 3.25, 3.40	AD246 / CAMELBACK
Mack	S652 (NSV only)	65,000lbs (29.5t)	5.22, 5.88	n/a	AD260 / CAMELBACK
Meritor	RT40-145	40,000lbs (18t)	4.33, 4.63	3.07, 3.21, 3.42	MaxLite 40 / AL460 / MIL-M
Meritor	RT46-160	46,000lbs (21t)	4.30, 4.56, 4.89	3.07, 3.21, 3.42	AL460/AP460/AD246/MIL-H
Meritor	RT50-160	50,000lbs (23t)	4.30, 4.56, 4.89	3.07, 3.21, 3.42	AP460/AD246 (NSV only)
Meritor	RT52-185	52,000lbs (23.6t)	4.30, 4.56, 4.89, 5.38	n/a	AD260 / MIL-X

** Mack ratios in **RED** relate to Mack 150 series carriers/Mack ratios in **BLACK** relate to Mack 200 series carriers

CHASSIS					
CHASSIS					
<div> <ul style="list-style-type: none">Advantage 300mm x 90mm x 7mm¹ 138,000psi/RBM 1,730,000in lb Advantage 300mm x 90mm x 8mm¹ 156,000psi/RBM 1,940,000in lb Advantage 300mm x 90mm x 9.5mm¹ 184,000psi/RBM 2,240,000in lb Advantage 300mm x 90mm x 11.1mm¹ 212,000psi/RBM 2,590,000in lb </div>					
¹ Dependant on wheel base and axle capacity					
WHEELBASE (WB)					
<div> <ul style="list-style-type: none">4,460mm (175.6") to 6,150mm (242") </div>					
AFTERFRAME (RO)					
<div> <ul style="list-style-type: none">1,460mm (57.5") to 2,810mm (110.6") rear overhang All chassis lengths can be specified with tapered rail ends </div>					

CAB SUPPORT					
<div> <ul style="list-style-type: none">Front: Two metalistic pivot mounts Rear: Air isolation with dual shock absorbers Rear panard rod (optional) </div>					
FRONT BUMPER/FUPS					
<div> <ul style="list-style-type: none">Light weight alloy bumper (standard) Polished alloy fold-down bullbar (optional) Temporary transit bar (optional) Front Underrun Protection (optional) </div>					
AIR TANK					
<div> <ul style="list-style-type: none">1 x steel tank mounted to the frame with manual drain cords (6x4 standard) 2 x steel tanks mounted to the frame with manual drain cords (8x4 standard) </div>					

WHEELS					
<div> <ul style="list-style-type: none">10-stud 8¼" (285mm PCD) steel disc 10-stud 8¼" (285mm PCD) machine buff disc 10-stud 8¼" (285mm PCD) polished alloy disc 10-stud 8¼" (285mm PCD) DURABRIGHT alloy disc 10-stud 9" (285mm PCD) polished alloy disc 10-stud 9" Offset (285mm PCD) polished alloy disc 10-stud 9" (285mm PCD) DURABRIGHT alloy disc 10-stud 9" Offset (285mm PCD) DURABRIGHT alloy disc </div>					

CAB					
SHELL					
<div> <ul style="list-style-type: none">Fusion Cab, ECE29 (cab crash test) compliant Two piece windscreen (standard) One piece windscreen (optional) </div>					
SLEEPER OPTIONS					
<div> <ul style="list-style-type: none">710mm (28") Super Cab with rear cabin extension 1,015mm (40") Mid-rise premium sleeper – 4 door 1,170mm (46") Mid-rise premium sleeper – 4 door 1,170mm (46") High-rise premium sleeper – 4 door Other sleeper dimensions (NSV only) </div>					

CAB INTERIOR					
<div> <ul style="list-style-type: none">Grey roof trim with 3 overhead storage pockets and 4 cabin lamps, complimentary Diamond Plate door trims (standard) Rear wall and 2 door storage pockets Dash: Charcoal dash with integrated cup holders Insulation: internal heat/noise rejection lining Key lock (standard) or remote control locking (optional) Manual (standard) or Power windows (optional) Slate grey pleated roof trim with overhead console and matching door trims – includes sleeper trim (optional) Burgundy pleated roof trim with overhead console and matching door trims – includes sleeper trim (optional) Wood grain dash finish (optional) Insulation: internal heat/noise rejection lining (standard) Floor: Black rubber mat (standard) </div>					
SEATS					
<div> <ul style="list-style-type: none">Driver: ISRI 'Big-Boy' air-ride (standard): cloth trim, upper, side and lower lumbar support with fore/aft seat cushion adjustment Driver: ISRI 'Big-Boy' air-ride Premium (optional): 'MACK' embossed cloth trim, LH arm rest, upper, side and lower lumbar support with oscillating base and fore/aft seat cushion adjustment Passenger: ISRI fixed cushion (standard) Passenger: ISRI premium air ride seat with upper and lower lumbar support, and fore/aft seat cushion adjustment (optional) </div>					

CAB EXTERIOR					
<div> <ul style="list-style-type: none">Fibreglass bonnet and polyfibre fenders with splash aprons Bonnet tilts forward 75° with spring assist Chrome grille surround and side air intakes (standard) Black nylon bonnet hold down straps (standard) Bright finish bonnet hold down straps (optional) Stainless bug screen integrated with grille (standard) Painted external survisor (standard) </div>					

HEADLAMPS					
<div> <ul style="list-style-type: none">Hella integral light/indicator unit with polycarbonate protective moulding </div>					
MARKER & TAIL LAMPS					
<div> <ul style="list-style-type: none">5 roof-mounted amber lights and 3 in 1 tail lamp (standard) LED roof clearance and tail lamps (optional) </div>					
REVERSING ALARM					
<div> <ul style="list-style-type: none">Chassis mounted back up alarm (optional) </div>					
REVOLVING ROOF BEACON					
<div> <ul style="list-style-type: none">Single amber revolving roof beacon (optional) </div>					
HOOK UP LAMP					
<div> <ul style="list-style-type: none">Rear of cab mounted hook up lamp (optional) </div>					

MIRRORS					
<div> <ul style="list-style-type: none">Heated 'West Coast' mirrors with stainless steel arms (standard) LH and RH power mirrors (optional) LH and RH 7" spotter mirrors (standard) LH down mirror (optional) </div>					
WINDSCREEN STONE GUARD					
<div> <ul style="list-style-type: none">Electronic variable-speed, intermittent wipers with washer Reservoir mounted under bonnet </div>					

PAINT & ACCESSORIES					
PAINT TYPE AND COLOUR					
<div> <ul style="list-style-type: none">Cab/sleeper: Single non-metallic cab colour PPG – Mack White and Mack Black Chassis: Single non-metallic chassis colour Alternative metallic and non-metallic colours (NSV only) Epoxy Mine specification primer (NSV only) </div>					
ACCESSORIES					
<div> <ul style="list-style-type: none">Many factory fitted accessories which are not listed, are also available All customers are encouraged to see their Authorised Dealer for full details </div>					

AUDIO SYSTEM					
<div> <ul style="list-style-type: none">Base Radio/CD player 4 x 20watt (standard) Premium Radio/CD player 4 x 35watt including hands free (opt) iPod connector and USB connector (optional) </div>					

COMMUNICATIONS					
<div> <ul style="list-style-type: none">GME TX835 CB radio (optional) GME TX4400 UHF radio (optional) NSV with <i>m</i>DRIVE </div>					

CLIMATE CONTROL					
<div> <ul style="list-style-type: none">HVAC integral cab air conditioner/heater Electronic controls Replaceable dust intrusion filter </div>					

COURTESY LAMPS					
<div> <ul style="list-style-type: none">Drivers/Passengers door entry lighting </div>					

SAFETY & WARNING					
<div> <ul style="list-style-type: none">Set of 3 safety warning triangles (optional) Door mounted emergency procedure guide (optional) Emergency eye wash bottle (optional) 2.5kg in cab mounted fire extinguisher (optional) 9kg on frame mounted fire extinguisher (optional) </div>					

TYRE EQUIPMENT					
<div> <ul style="list-style-type: none">20 tonne bottle jack (optional) Wheel lug wrench kit (optional) </div>					