

GRANITE

THE NO-NONSENSE ALL ROUNDER.

A tough, no-nonsense, workhorse. The Granite is all about getting the job done in heavy traffic, on open highways or around the toughest construction sites.

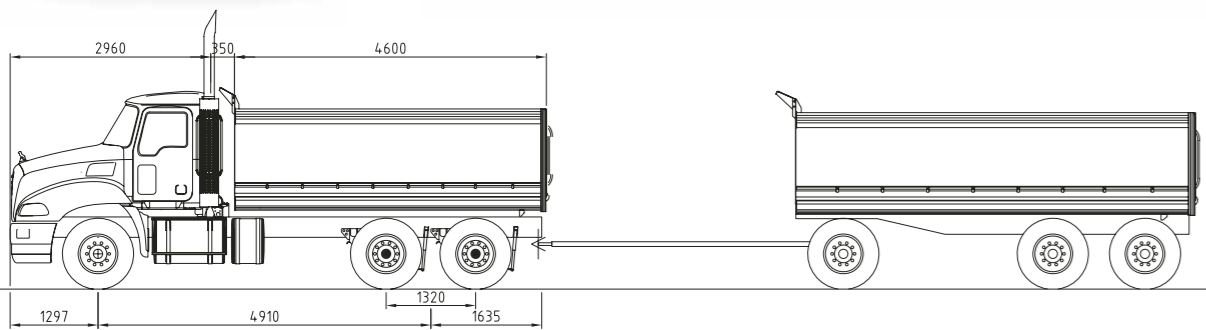

GRANITE 6X4 DAY CAB WITH TIPPER & 3-AXLE DOG

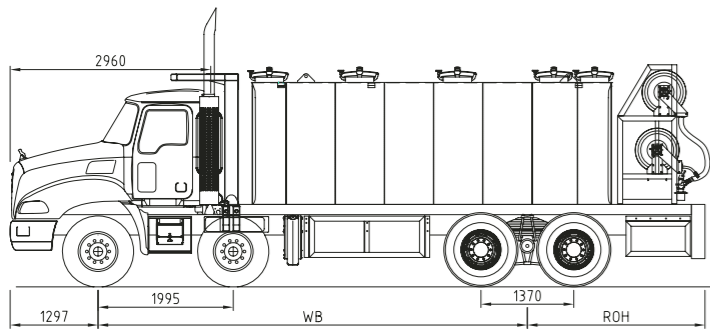

GRANITE 8X4 MINE SERVICE UNIT

GRANITE WHEELBASE CHART

WHEELBASE* (WB)	EXHAUST TO CENTRE OF DRIVE (mm), CA**	MAXIMUM FUEL CAPACITY***	ADBLUE TANK CAP	TURNING CIRCLE (m)****
	Day Cab			Kerb to Kerb
BBC	2960			
6x4				
5510mm (Rigid Only)	3727	850L	125L	19.2
5810mm (Rigid Only)	4027	850L	125L	20.1
6110mm (Rigid Only)	4327	850L	125L	21.0
8x4				
5410mm	3627	350L	60L	20.2
5710mm	3927	500L	60L	21.2
6110mm (Rigid Only)	4327	500L	60L	22.5

GVM: Up to 30,000kg[†] GCM: Up to 106 tonnes[†]

* Wheelbases calculated using 1320mm Bogie Spread.

** Distances shown are with rear exhausts Day Cab or forward mounted exhausts for sleeper.

*** Maximum fuel capacity is VSS selectable combinations with batteries mounted on chassis for day cab and inframe or in sleeper.

**** Turning circle measure to be used as a guide only. Refer to WIS.

† Subject to application.



MACKTRUCKS.COM.AU

Granite-V-08-2011 Printed in Australia

The information in this brochure was current at the time of publication. Mack Trucks reserves the right to make changes in specifications, equipment and design, or to discontinue models, options or extras without notice at any time. MACK and the Bulldog design are registered trademarks. All rights reserved. V-MAC is a registered trademark. All rights reserved.



GRANITE

VOCATIONAL

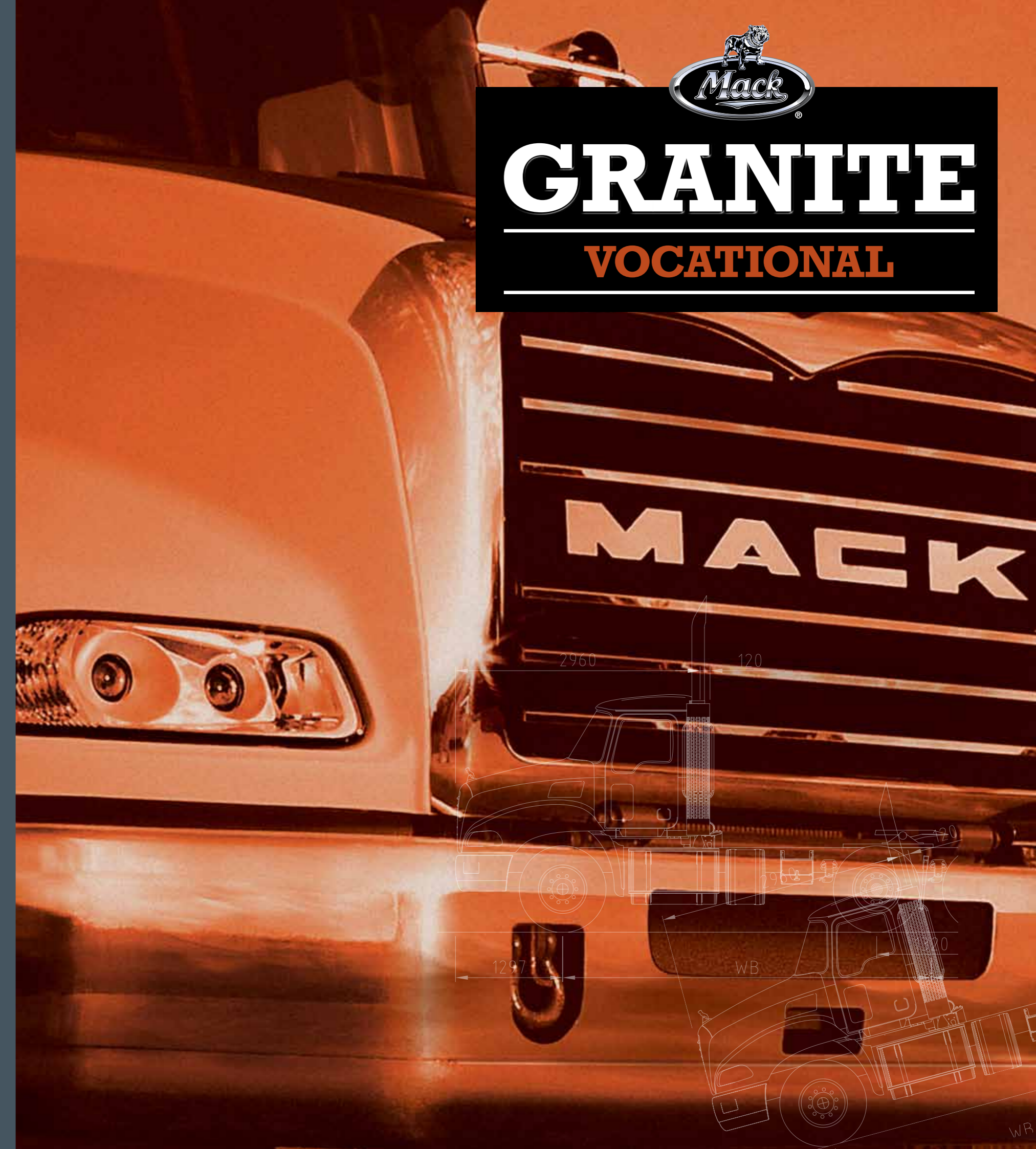

ENGINE & TRANSMISSION			
ENGINE			
<div><ul style="list-style-type: none">Mack MP8 12.8 litreMaxi-Cruise torque settingsSelective Catalytic Reduction (SCR)Emission Level Euro5 (ADR80/03)</div>			
Horsepower (Hp)	435	500	
Torque (lb–ft)	1655	1840	
ENGINE BRAKE			
<div><ul style="list-style-type: none">Powerleash engine brakeEngine retarding power up to 315Kw (495hp) @ 2,100rpm</div>			
AIR INTAKE & FILTER			
<div><ul style="list-style-type: none">Donaldson 279mm (11") Single dry type elementUnder bonnet air intake</div>			
FILTERS			
<div><ul style="list-style-type: none">2 full flow and 1 bypass engine mounted oil filters2 step dual engine mounted fuel filters/water separator</div>			
AIR COMPRESSOR			
<div><ul style="list-style-type: none">2 CYL. 900 litres/min WABCO compressor</div>			
AIR DRYER			
<div><ul style="list-style-type: none">Bendix AD-IS air dryer</div>			
ALTERNATOR			
<div><ul style="list-style-type: none">Leece Neville 12volt/160Amp Brushless (standard)Leece Neville 12volt/185Amp Brushless (optional)</div>			
STARTER			
<div><ul style="list-style-type: none">Delco Remy 39MTHD 12volt electric starter (standard)Key type start and stop</div>			

TRANSMISSION CHART						
MAKE	MODEL	MAX TORQUE CAPACITY	FWD GEARS	REV GEARS	LO/HI	TYPE
Mack	T310MLR	1,800ft–lbs	10	6	27.30/0.71	Manual
Mack	T318	1,800ft–lbs	18	3	13.44/0.71	Manual
Mack	T31821	2,100ft–lbs	18	3	13.44/0.71	Manual
Mack <i>mDRIVE</i>	<i>Tm</i> D12AD (Direct)	1,920ft–lbs	12	2	14.94/1.0	Fully Automated
Fuller	RTL016918	1,650ft–lbs	18	4	14.40/0.73	Manual
Fuller	RTL018918	1,850ft–lbs	18	4	14.40/0.73	Manual
Fuller	RTL020918	2,050ft–lbs	18	4	14.40/0.73	Manual

Note: RTL016918 & MP8 435hp <50tonnes, RTL018918 & MP8 500hp <50tonnes

AXLES & SUSPENSION	
FRONT AXLE	
<div><ul style="list-style-type: none">Mack FXL with unitised hubs (Refer Steer Axle Chart)Axle position: Axle Back (AB) 1,297mm BFA</div>	
FRONT SUSPENSION	
<div><ul style="list-style-type: none">1,321mm (52") long springs (Refer Steer Axle Chart)</div>	
FRONT BRAKES	
<div><ul style="list-style-type: none">Front automatic slack adjustersType 20 brake boostersType 24 brake boostersS' Cam with iron drums (standard)S' Cam with centrifuse drums (optional)</div>	
STEERING GEAR	
<div><ul style="list-style-type: none">Sheppard M100PSteering ratio 18.9:1</div>	

FAN	
<div><ul style="list-style-type: none">Behr Visco Drive (electric over viscous fan clutch)750mm (29.5") 9-blade nylon fan</div>	
RADIATOR	
<div><ul style="list-style-type: none">NL3, Frontal area 1,435in²</div>	
EXHAUST	
<div><ul style="list-style-type: none">Single RHS frame mounted catalyst with stainless heat shield<ul style="list-style-type: none">Outlet single RHS 152mm (6") vertical exhaust (Day Cab)Outlet twin 152mm (6") vertical exhaust (Day Cab)Outlet single LHS 152mm (6") vertical exhaust (Sleeper Cab)Outlet single 127mm (5") underframe outlet (optional)Exhaust tip height above ground 3.5mtr (standard)Exhaust tip height above ground 4.2mtr (optional)</div>	
TRANSMISSION	
<div><ul style="list-style-type: none">Manual and Automated transmissions (Refer Transmission Chart)Transmission oil cooler (standard)</div>	
CLUTCH	
<div><ul style="list-style-type: none">Eaton 394mm (15.5") Easy Pedal with VCT Plus (standard)Eaton ‘Solo’ with VCT Plus (optional)Single Plate 430mm (17") (standard with <i>mDRIVE</i>)Air assist clutch release (standard)</div>	
DRIVELINE	
<div><ul style="list-style-type: none">Spicer 1810 Main shafts, 1710 Inter-axle1810 interaxle and SPL driveline (NSV only)</div>	
PTO OPTIONS	
<div><ul style="list-style-type: none">Rear of engine PTO (REPTO)Transmission mounted PTO (optional on <i>mDRIVE</i>)Prep kit, switch and wiring only (optional)</div>	

AXLES & SUSPENSION (CONTINUED)	
INTER-AXLE/WHEEL LOCKS	
<div><ul style="list-style-type: none">DCDL one axle only (vendor axles only)DCDLs on both axles (optional on Mack and vendor)Mack Power Divider (standard with Mack axles)</div>	
TYRES	
<div><ul style="list-style-type: none">Michelin tyres as standard</div>	

STEER AXLE CHART					
MAKE	MODEL	CAPACITY	SUSPENSION*	COMMENTS	
Mack	FXL 14.6	14,600lbs (6.6t)	(P3,M7)	Standard axle	
Mack ^(Aus)	Twin FXL 14.6	29,200lbs (13t)	(P3)	Load share mechanical	
Mack ^(NZ)	Twin FXL 14.6	29,200lbs (13t)	(P3)	Non-load share mechanical	
Mack	FXL 18	18,000lbs (8.2t)	(H8)	For heavy-duty applications	
Mack	FXL 20	20,000lbs (9.1t)	(P4,M8,H10)	For extra heavy-duty applications	
Meritor	FG941 ^(NSV only)	14,600lbs (6.6t)	(P3,M7)	Disc brakes ^(NSV only)	

* Parabolic Standard Duty (P), Multileaf Standard Duty (M), Multileaf Heavy Duty (H) – Number = Leaf Qty

DRIVE AXLE CHART					
MAKE	MODEL	CAPACITY	RATIOS**	RATIOS (<i>mDRIVE</i>)	SUSPENSION
Mack	S440	44,000lbs (20t)	4.35, 4.73, 5.02 / 4.19, 4.50, 4.80	3.11, 3.25, 3.40	AL460
Mack	S462	46,000lbs (21t)	4.35, 4.73, 5.02 / 4.19, 4.50, 4.80	3.11, 3.25, 3.40	AD246 / CAMELBACK
Mack	S652 ^(NSV only)	65,000lbs (29.5t)	5.22, 5.88	n/a	AD260 / CAMELBACK
Meritor	RT40-145	40,000lbs (18t)	4.33, 4.63	3.07, 3.21, 3.42	MaxLite 40 / AL460 / MIL-M
Meritor	RT46-160	46,000lbs (21t)	4.30, 4.56, 4.89	3.07, 3.21, 3.42	AL460/AP460/AD246/MIL-H
Meritor	RT50-160	50,000lbs (23t)	4.30, 4.56, 4.89	3.07, 3.21, 3.42	AP460 / AD246 ^(NSV only)
Meritor	RT52-185	52,000lbs (23.6t)	4.30, 4.56, 4.89, 5.38	n/a	AD260 / MIL-X

** Mack ratios in **RED** relate to Mack 150 series carriers/Mack ratios in **BLACK** relate to Mack 200 series carriers

CHASSIS	
CHASSIS	
<div><ul style="list-style-type: none">Advantage 300mm x 90mm x 7mm[†] 138,000psi/RBM 1,730,000in lbAdvantage 300mm x 90mm x 8mm[†] 156,000psi/RBM 1,940,000in lbAdvantage 300mm x 90mm x 9.5mm[†] 184,000psi/RBM 2,240,000in lbAdvantage 300mm x 90mm x 11.1mm[†] 212,000psi/RBM 2,590,000in lb</div> [†] Dependant on wheel base and axle capacity	
WHEELBASE (WB)	
<div><ul style="list-style-type: none">5,410mm (213") to 6,035mm (237.6")</div>	
AFTERFRAME (RO)	
<div><ul style="list-style-type: none">1,460mm (57.5") to 2,810mm (110.6") rear overhangAll chassis lengths can be specified with tapered rail ends</div>	
CAB SUPPORT	
<div><ul style="list-style-type: none">Front: Two metallic pivot mountsRear: Air isolation with dual shock absorbersRear panard rod (optional)</div>	
FRONT BUMPER/FUPS	
<div><ul style="list-style-type: none">Light weight alloy bumper (standard)Polished alloy fold-down bullbar (optional)Temporary transit bar (optional)Front Underrun Protection (optional)</div>	
AIR TANK	
<div><ul style="list-style-type: none">1 x steel tank mounted to the frame with manual drain cords (6x4 standard)2 x steel tanks mounted to the frame with manual drain cords (8x4 standard)</div>	

WHEELS	
<div><ul style="list-style-type: none">10-stud 8¼" (285mm PCD) steel disc10-stud 8¼" (285mm PCD) machine buff disc10-stud 8¼" (285mm PCD) polished alloy disc10-stud 8¼" (285mm PCD) DURABRIGHT alloy disc10-stud 9" (285mm PCD) polished alloy disc10-stud 9" Offset (285mm PCD) polished alloy disc10-stud 9" (285mm PCD) DURABRIGHT alloy disc10-stud 9" Offset (285mm PCD) DURABRIGHT alloy disc</div>	

CAB	
SHELL	
<div><ul style="list-style-type: none">Fusion Cab, ECE29 (cab crash test) compliantTwo piece windscreen (standard)One piece windscreen (optional)</div>	
SLEEPER OPTIONS	
<div><ul style="list-style-type: none">710mm (28") Super Cab with rear cabin extension1,015mm (40") Mid-rise premium sleeper – 4 door1,170mm (46") Mid-rise premium sleeper – 4 door1,170mm (46") High-rise premium sleeper – 4 doorOther sleeper dimensions (NSV only)</div>	
CAB INTERIOR	
<div><ul style="list-style-type: none">Grey roof trim with 3 overhead storage pockets and 4 cabin lamps, complimentary Diamond Plate door trims (standard)Rear wall and 2 door storage pocketsDash: Charcoal dash with integrated cup holdersInsulation: internal heat/noise rejection liningKey lock (standard) or remote control locking (optional)Manual (standard) or Power windows (optional)Slate grey pleated roof trim with overhead console and matching door trims (optional)Burgundy pleated roof trim with overhead console and matching door trims (optional)Wood grain dash finish (optional)Insulation: internal heat/noise rejection lining (standard)Floor: Black rubber mat (standard)</div>	
SEATS	
<div><ul style="list-style-type: none">Driver: ISRI ‘Big-Boy’ air-ride (standard): cloth trim, upper, side and lower lumbar support with fore/aft seat cushion adjustmentDriver: ISRI ‘Big-Boy’ air-ride Premium (optional): ‘MACK’ embossed cloth trim, LH arm rest, upper, side and lower lumbar support with oscillating base and fore/aft seat cushion adjustmentPassenger: ISRI fixed cushion (standard)Passenger: ISRI premium air ride seat with upper and lower lumbar support, and fore/aft seat cushion adjustment (optional)</div>	
STEERING WHEEL	
<div><ul style="list-style-type: none">Bulldog soft touch rubber grip 457mm (18") diameter (standard)Elite leather grip steering wheel (optional)Adjustable tilt and telescopic steering column</div>	
INSTRUMENTS & STANDARD GAUGES	
<div><ul style="list-style-type: none">Driver information display: Co-PilotSpeedometer/odometer (electronic)Tachometer/hourmeter (electronic)Voltmeter, engine hours, distance, trip recordingEngine coolant temperature, fuel levelPrimary and secondary air pressureOil pressure and oil temperature</div>	
FULL GAUGE PACKAGE INCLUDES (OPTIONAL)	
<div><ul style="list-style-type: none">Manifold pressure, transmission temperature, exhaust temperature, brake application pressure, front and rear drive axle temperature</div>	
WINDSCREEN WIPERS	
<div><ul style="list-style-type: none">Electronic variable-speed, intermittent wipers with washerReservoir mounted under bonnet</div>	
PAINT & ACCESSORIES	
PAINT TYPE AND COLOUR	
<div><ul style="list-style-type: none">Cab/sleeper: Single non-metallic cab colourPPG – Mack White and Mack BlackChassis: Single non-metallic chassis colourAlternative metallic and non-metallic colours (NSV only)Epoxy Mine specification primer (NSV only)</div>	

AUDIO SYSTEM	
<div><ul style="list-style-type: none">Base Radio/CD player 4 x 20watt (standard)Premium Radio/CD player 4 x 35watt including hands free (opt)iPod connector and USB connector (optional)</div>	

COMMUNICATIONS	
<div><ul style="list-style-type: none">GME TX835 CB radio (optional)GME TX4400 UHF radio (optional) NSV with <i>mDRIVE</i></div>	

CLIMATE CONTROL	
<div><ul style="list-style-type: none">HVAC integral cab air conditioner/heaterElectronic controlsReplaceable dust intrusion filter</div>	

COURTESY LAMPS	
<div><ul style="list-style-type: none">Drivers/Passengers door entry lighting</div>	

SAFETY & WARNING	
<div><ul style="list-style-type: none">Set of 3 safety warning triangles (optional)Door mounted emergency procedure guide (optional)Emergency eye wash bottle (optional)2.5kg in cab mounted fire extinguisher (optional)9kg on frame mounted fire extinguisher (optional)</div>	

TYRE EQUIPMENT	
<div><ul style="list-style-type: none">20 tonne bottle jack (optional)Wheel lug wrench kit (optional)</div>	

CAB EXTERIOR	
<div><ul style="list-style-type: none">Fibreglass bonnet and polyfibre fenders with splash apronsBonnet tilts forward 75° with spring assistChrome grille surround and side air intakes (standard)Black nylon bonnet hold down straps (standard)Bright finish bonnet hold down straps (optional)Stainless bug screen integrated with grille (standard)Painted external sunvisor (standard)</div>	

HEADLAMPS	
<div><ul style="list-style-type: none">Hella integral light/indicator unit with polycarbonate protective moulding</div>	

MARKER & TAIL LAMPS	
<div><ul style="list-style-type: none">5 roof-mounted amber lights and 3 in 1 tail lamp (standard)LED roof clearance and tail lamps (optional)</div>	

REVERSING ALARM	
<div><ul style="list-style-type: none">Chassis mounted back up alarm (optional)</div>	

REVOLVING ROOF BEACON	
<div><ul style="list-style-type: none">Single amber revolving roof beacon (optional)Dual amber revolving roof beacon (optional on sleeper)</div>	

HOOK UP LAMP	
<div><ul style="list-style-type: none">Rear of cab mounted hook up lamp (optional)</div>	

MIRRORS	
<div><ul style="list-style-type: none">Heated ‘West Coast’ mirrors with stainless steel arms (standard)LH and RH power mirrors (optional)LH and RH 7" spotter mirrors (standard)LH down mirror (optional)</div>	

WINDSCREEN STONE GUARD	
<div><ul style="list-style-type: none">Matt black mesh windscreen stone guard (optional)</div>	

ACCESSORIES	
<div><ul style="list-style-type: none">Many factory fitted accessories which are not listed, are also availableAll customers are encouraged to see their Authorised Dealer for full details</div>	