

# TRIDENT

## GOOD LOOKS, MUSCLES AND MANNERS.

Easy on the eye. Strong and versatile. The Trident packs a punch with productivity and performance in construction, on-road or anywhere in between.

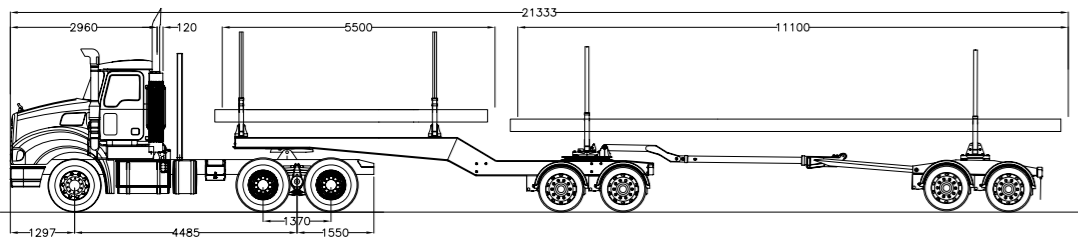

TRIDENT 6X4 AB DAY CAB WITH B-DOUBLE LOG JINKERS

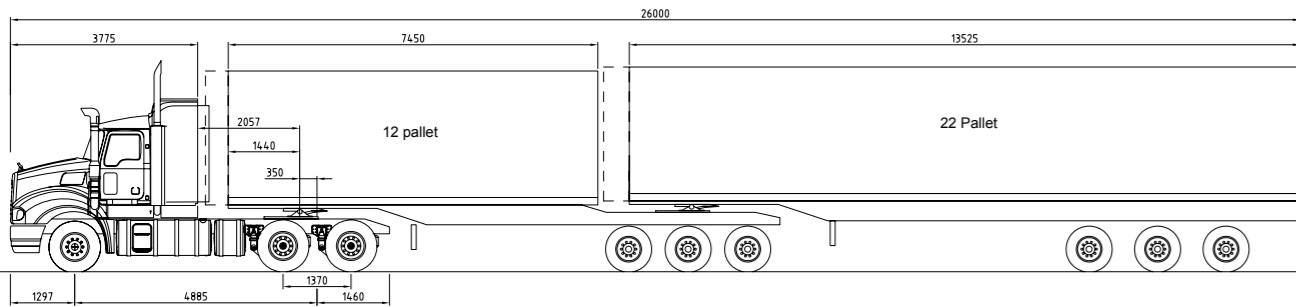

TRIDENT 6X4 AB 40" MID RISE SLEEPER WITH 26M B-DOUBLE

### TRIDENT AB WHEELBASE CHART

WHEELBASE* (WB)	EXHAUST TO CENTRE OF DRIVE (mm), CA**					MAXIMUM FUEL CAPACITY***	ADBLUE TANK CAP	TURNING CIRCLE (m)****
	Day Cab	Super Cab	40" Sleeper	46" Sleeper	52" Sleeper			
<b>BBC</b>	2960	3570	3775	3930	4080			<b>Kerb to Kerb</b>
4460mm	2677					700L	125L	15.9
4710mm	2877	2387	2182			1000L	125L	16.7
4860mm	3077	2587	2382	2227		1400L	200L	17.2
5060mm			2582	2427	2277	1400L	200L	17.8
5210mm				2577	2427	1400L	200L	18.3
5360mm					2577	1700L	150L	18.7

GVM: Up to 26,000kg<sup>†</sup> GCM: Up to 131 tonnes<sup>†</sup>

\* Wheelbase calculated using 1320mm Bogie Spread.

\*\* Distances shown are with rear exhausts Day Cab or forward mounted exhausts for sleeper.

\*\*\* Maximum fuel capacity is VSS selectable combinations with batteries mounted on chassis for day cab and inframe or in sleeper for larger cabs.

\*\*\*\* Turning circle measure to be used as a guide only. Refer to WIS.

† Subject to application.



MACKTRUCKS.COM.AU

Trident-AB-08-2011 Printed in Australia

The information in this brochure was current at the time of publication. Mack Trucks reserves the right to make changes in specifications, equipment and design, or to discontinue models, options or extras without notice at any time. MACK and the Bulldog design are registered trademarks. All rights reserved. V-MAC is a registered trademark. All rights reserved.



# TRIDENT

## AXLE BACK



ENGINE & TRANSMISSION								
<div><b>ENGINE</b></div> <ul style="list-style-type: none"><li>▶ MACK MP8 12.8 litre</li> <li>▶ MAXI-CRUISE torque settings</li> <li>▶ Selective Catalytic Reduction (SCR)</li> <li>▶ Emission Level Euro5 (ADR80/03)</li></ul>								
<table> <tbody><tr> <td>Horsepower (Hp)</td> <td>500</td> <td>535</td> <td></td></tr> <tr> <td>Torque (lb–ft)</td> <td>1840</td> <td>1920</td> <td></td></tr> </tbody></table>	Horsepower (Hp)	500	535		Torque (lb–ft)	1840	1920	
Horsepower (Hp)	500	535						
Torque (lb–ft)	1840	1920						
<div><b>ENGINE BRAKE</b></div> <ul style="list-style-type: none"><li>▶ Powerleash engine brake</li> <li>▶ Engine retarding power up to 315Kw (495hp) @ 2,100rpm</li></ul>								
<div><b>AIR INTAKE &amp; FILTER</b></div> <ul style="list-style-type: none"><li>▶ Donaldson 279mm (11") single dry type element, mounted under bonnet</li> <li>▶ Painted steel dust extractors and external raised air intakes mounted in front of the cabin 'A' pillars</li></ul>								
<div><b>FILTERS</b></div> <ul style="list-style-type: none"><li>▶ 2 full flow and 1 bypass engine mounted oil filters</li> <li>▶ 2 step dual engine mounted fuel filters/water separator</li></ul>								
<div><b>AIR COMPRESSOR</b></div> <ul style="list-style-type: none"><li>▶ 2 CYL. 900litres/min WABCO compressor</li></ul>								
<div><b>AIR DRYER</b></div> <ul style="list-style-type: none"><li>▶ Bendix AD-IS air dryer</li></ul>								
<div><b>ALTERNATOR</b></div> <ul style="list-style-type: none"><li>▶ Leece Neville 12volt/160Amp Brushless (standard)</li> <li>▶ Leece Neville 12volt/185Amp Brushless (optional)</li></ul>								
<div><b>STARTER</b></div> <ul style="list-style-type: none"><li>▶ Delco 39MTHD 12volt electric starter (standard)</li> <li>▶ Key type start and stop</li></ul>								

TRANSMISSION CHART																																																	
<table> <tbody><tr> <th>MAKE</th> <th>MODEL</th> <th>MAX TORQUE CAPACITY</th> <th>FWD GEARS</th> <th>REV GEARS</th> <th>LO/HI</th> <th>TYPE</th></tr> <tr> <td>Mack</td> <td>T31821</td> <td>2,100ft–lbs</td> <td>18</td> <td>3</td> <td>13.44/0.71</td> <td>Manual</td></tr> <tr> <td>Mack <i>m</i>DRIVE</td> <td><i>Tm</i>D12AD (Direct)</td> <td>1,920ft–lbs</td> <td>12</td> <td>2</td> <td>14.94/1.0</td> <td>Fully Automated</td></tr> <tr> <td>Eaton</td> <td>RTLO18918</td> <td>1,850ft–lbs</td> <td>18</td> <td>4</td> <td>14.40/0.73</td> <td>Manual</td></tr> <tr> <td>Eaton</td> <td>RTLO20918</td> <td>2,050ft–lbs</td> <td>18</td> <td>4</td> <td>14.40/0.73</td> <td>Manual</td></tr> <tr> <td>Eaton</td> <td>RTLO22918</td> <td>2,250ft–lbs</td> <td>18</td> <td>4</td> <td>14.40/0.73</td> <td>Manual</td></tr> <tr> <td colspan="7">Note: RTLO18918 and MP8 500hp &lt;50tonnes, RTLO20918 and MP8 535hp &lt;60tonnes</td></tr> </tbody></table>	MAKE	MODEL	MAX TORQUE CAPACITY	FWD GEARS	REV GEARS	LO/HI	TYPE	Mack	T31821	2,100ft–lbs	18	3	13.44/0.71	Manual	Mack <i>m</i> DRIVE	<i>Tm</i> D12AD (Direct)	1,920ft–lbs	12	2	14.94/1.0	Fully Automated	Eaton	RTLO18918	1,850ft–lbs	18	4	14.40/0.73	Manual	Eaton	RTLO20918	2,050ft–lbs	18	4	14.40/0.73	Manual	Eaton	RTLO22918	2,250ft–lbs	18	4	14.40/0.73	Manual	Note: RTLO18918 and MP8 500hp <50tonnes, RTLO20918 and MP8 535hp <60tonnes						
MAKE	MODEL	MAX TORQUE CAPACITY	FWD GEARS	REV GEARS	LO/HI	TYPE																																											
Mack	T31821	2,100ft–lbs	18	3	13.44/0.71	Manual																																											
Mack <i>m</i> DRIVE	<i>Tm</i> D12AD (Direct)	1,920ft–lbs	12	2	14.94/1.0	Fully Automated																																											
Eaton	RTLO18918	1,850ft–lbs	18	4	14.40/0.73	Manual																																											
Eaton	RTLO20918	2,050ft–lbs	18	4	14.40/0.73	Manual																																											
Eaton	RTLO22918	2,250ft–lbs	18	4	14.40/0.73	Manual																																											
Note: RTLO18918 and MP8 500hp <50tonnes, RTLO20918 and MP8 535hp <60tonnes																																																	

AXLES & SUSPENSION
<div><b>FRONT AXLE</b></div> <ul style="list-style-type: none"><li>▶ Mack FXL with unitised hubs (Refer Steer Axle Chart)</li> <li>▶ Axle position: Axle back (AB): 1,297mm BFA</li></ul>
<div><b>FRONT SUSPENSION</b></div> <ul style="list-style-type: none"><li>▶ 1,321mm (52") long springs (Refer Steer Axle Chart)</li></ul>
<div><b>FRONT BRAKES</b></div> <ul style="list-style-type: none"><li>▶ Front automatic slack adjusters</li> <li>▶ Type 24 brake boosters</li> <li>▶ S' Cam with iron drums (standard)</li> <li>▶ S' Cam with centrifuse drums (optional)</li></ul>
<div><b>STEERING GEAR</b></div> <ul style="list-style-type: none"><li>▶ Sheppard M100P</li> <li>▶ Steering ratio 18.9:1</li></ul>
<div><b>REAR AXLES</b></div> <ul style="list-style-type: none"><li>▶ Mack, Meritor and Dana axle options (Refer Drive Axle Chart)</li> <li>▶ Ratings 20 to 22.7 tonne</li></ul>

<div><b>FAN</b></div> <ul style="list-style-type: none"><li>▶ Behr Visco drive (electric over viscous fan clutch)</li> <li>▶ 750mm (29.5") 9-blade nylon fan (AB)</li></ul>
<div><b>RADIATOR</b></div> <ul style="list-style-type: none"><li>▶ NL3, Frontal area 1,435in²</li></ul>
<div><b>EXHAUST</b></div> <ul style="list-style-type: none"><li>▶ Single RHS frame mounted catalyst with stainless heat shield <ul style="list-style-type: none"><li>▶ Outlet single RHS 152mm (6") vertical exhaust (Day Cab)</li> <li>▶ Outlet twin 152mm (6") vertical exhaust (Day Cab)</li> <li>▶ Outlet twin 152mm (6") vertical exhaust (Sleeper Cab)</li> <li>▶ Outlet single 127mm (5") underframe outlet (optional)</li></ul></li> <li>▶ Exhaust tip height above ground 3.5mtr (standard)</li> <li>▶ Exhaust tip height above ground 4.2mtr (optional)</li></ul>
<div><b>TRANSMISSION</b></div> <ul style="list-style-type: none"><li>▶ Manual and Automated transmissions (Refer Transmission Chart)</li> <li>▶ Transmission oil cooler (optional)</li></ul>
<div><b>CLUTCH</b></div> <ul style="list-style-type: none"><li>▶ Eaton 394mm (15.5") Easy Pedal with VCT Plus (standard)</li> <li>▶ Eaton 'Solo' with VCT Plus (optional)</li> <li>▶ Single Plate 430mm (17") (standard with <i>m</i>DRIVE)</li> <li>▶ Air assist clutch release</li></ul>
<div><b>DRIVELINE</b></div> <ul style="list-style-type: none"><li>▶ Spicer 1810 Main shafts, 1710 Inter-axle</li> <li>▶ 1810 interaxle and SPL driveline (NSV only)</li></ul>
<div><b>PTO OPTIONS</b></div> <ul style="list-style-type: none"><li>▶ Rear of engine PTO (REPTO)</li> <li>▶ Transmission mounted PTO (optional on <i>m</i>DRIVE)</li> <li>▶ Prep kit, switch and wiring only (optional)</li></ul>

AXLES & SUSPENSION (CONTINUED)
<div><b>WHEELS</b></div> <ul style="list-style-type: none"><li>▶ 10-stud 8¼" (285mm PCD) steel disc</li> <li>▶ 10-stud 8¼" (285mm PCD) machine buff disc</li> <li>▶ 10-stud 8¼" (285mm PCD) polished alloy disc</li> <li>▶ 10-stud 8¼" (285mm PCD) DURABRIGHT alloy disc</li> <li>▶ 10-stud 9" (285mm PCD) polished alloy disc</li></ul>
<div><b>WHEELS (CONTINUED)</b></div> <ul style="list-style-type: none"><li>▶ 10-stud 9" Offset (285mm PCD) polished alloy disc</li> <li>▶ 10-stud 9" (285mm PCD) DURABRIGHT alloy disc</li> <li>▶ 10-stud 9" Offset (285mm PCD) DURABRIGHT alloy disc</li></ul>
<div><b>TYRES</b></div> <ul style="list-style-type: none"><li>▶ Michelin tyres as standard</li></ul>

STEER AXLE CHART																									
<table> <tbody><tr> <th>MAKE</th> <th>MODEL</th> <th>CAPACITY</th> <th>SUSPENSION*</th> <th>COMMENTS</th></tr> <tr> <td>Mack</td> <td>FXL 14.6</td> <td>14,600lbs (6.6t)</td> <td>(P3,M7)</td> <td>Standard axle</td></tr> <tr> <td>Mack <i>(Aus)</i></td> <td>Twin FXL 14.6 (NSV only)</td> <td>29,200lbs (13t)</td> <td>(P3)</td> <td>Load share <sup>(NSV only)</sup></td></tr> <tr> <td>Mack <i>(NZ)</i></td> <td>Twin FXL 14.6 (NSV only)</td> <td>29,200lbs (13t)</td> <td>(P3)</td> <td>Non-load share <sup>(NSV only)</sup></td></tr> <tr> <td>Meritor</td> <td>FG941 (NSV only)</td> <td>14,600lbs (6.6t)</td> <td>(P3,M7)</td> <td>Disc brakes <sup>(NSV only)</sup></td></tr> </tbody></table>	MAKE	MODEL	CAPACITY	SUSPENSION*	COMMENTS	Mack	FXL 14.6	14,600lbs (6.6t)	(P3,M7)	Standard axle	Mack <i>(Aus)</i>	Twin FXL 14.6 (NSV only)	29,200lbs (13t)	(P3)	Load share <sup>(NSV only)</sup>	Mack <i>(NZ)</i>	Twin FXL 14.6 (NSV only)	29,200lbs (13t)	(P3)	Non-load share <sup>(NSV only)</sup>	Meritor	FG941 (NSV only)	14,600lbs (6.6t)	(P3,M7)	Disc brakes <sup>(NSV only)</sup>
MAKE	MODEL	CAPACITY	SUSPENSION*	COMMENTS																					
Mack	FXL 14.6	14,600lbs (6.6t)	(P3,M7)	Standard axle																					
Mack <i>(Aus)</i>	Twin FXL 14.6 (NSV only)	29,200lbs (13t)	(P3)	Load share <sup>(NSV only)</sup>																					
Mack <i>(NZ)</i>	Twin FXL 14.6 (NSV only)	29,200lbs (13t)	(P3)	Non-load share <sup>(NSV only)</sup>																					
Meritor	FG941 (NSV only)	14,600lbs (6.6t)	(P3,M7)	Disc brakes <sup>(NSV only)</sup>																					
* Parabolic Standard Duty (P), Multileaf Standard Duty (M), Multileaf Heavy Duty (H) – Number = Leaf Qty																									

DRIVE AXLE CHART																																				
<table> <tbody><tr> <th>MAKE</th> <th>MODEL</th> <th>CAPACITY</th> <th>RATIOS**</th> <th>RÁTIOS (<i>m</i>DRIVE)</th> <th>SUSPENSION</th></tr> <tr> <td>Mack</td> <td>S440</td> <td>44,000lbs (20t)</td> <td>4.35, 4.73, 5.02 / <b>4.19, 4.50, 4.80</b></td> <td>3.11, 3.25, 3.40</td> <td>AL460</td></tr> <tr> <td>Mack</td> <td>S462</td> <td>46,000lbs (21t)</td> <td>4.35, 4.73, 5.02 / <b>4.19, 4.50, 4.80</b></td> <td>3.11, 3.25, 3.40</td> <td>AD246 / CAMELBACK</td></tr> <tr> <td>Meritor</td> <td>RT46-160</td> <td>46,000lbs (21t)</td> <td>4.30, 4.56, 4.89</td> <td>3.07, 3.21, 3.42</td> <td>AL460/AP460/AD246/MIL-H</td></tr> <tr> <td>Dana</td> <td>D46-170</td> <td>46,000lbs (21t)</td> <td>4.30, 4.56, 4.78</td> <td>3.07, 3.21, 3.42</td> <td>AL460</td></tr> <tr> <td>Dana</td> <td>D50-170</td> <td>50,000lbs (22.7t)</td> <td>4.30, 4.56, 4.78</td> <td>3.07, 3.21, 3.42</td> <td>AD246</td></tr> </tbody></table>	MAKE	MODEL	CAPACITY	RATIOS**	RÁTIOS ( <i>m</i> DRIVE)	SUSPENSION	Mack	S440	44,000lbs (20t)	4.35, 4.73, 5.02 / <b>4.19, 4.50, 4.80</b>	3.11, 3.25, 3.40	AL460	Mack	S462	46,000lbs (21t)	4.35, 4.73, 5.02 / <b>4.19, 4.50, 4.80</b>	3.11, 3.25, 3.40	AD246 / CAMELBACK	Meritor	RT46-160	46,000lbs (21t)	4.30, 4.56, 4.89	3.07, 3.21, 3.42	AL460/AP460/AD246/MIL-H	Dana	D46-170	46,000lbs (21t)	4.30, 4.56, 4.78	3.07, 3.21, 3.42	AL460	Dana	D50-170	50,000lbs (22.7t)	4.30, 4.56, 4.78	3.07, 3.21, 3.42	AD246
MAKE	MODEL	CAPACITY	RATIOS**	RÁTIOS ( <i>m</i> DRIVE)	SUSPENSION																															
Mack	S440	44,000lbs (20t)	4.35, 4.73, 5.02 / <b>4.19, 4.50, 4.80</b>	3.11, 3.25, 3.40	AL460																															
Mack	S462	46,000lbs (21t)	4.35, 4.73, 5.02 / <b>4.19, 4.50, 4.80</b>	3.11, 3.25, 3.40	AD246 / CAMELBACK																															
Meritor	RT46-160	46,000lbs (21t)	4.30, 4.56, 4.89	3.07, 3.21, 3.42	AL460/AP460/AD246/MIL-H																															
Dana	D46-170	46,000lbs (21t)	4.30, 4.56, 4.78	3.07, 3.21, 3.42	AL460																															
Dana	D50-170	50,000lbs (22.7t)	4.30, 4.56, 4.78	3.07, 3.21, 3.42	AD246																															
** Mack ratios in <b>RED</b> relate to Mack 150 series carriers/Mack ratios in <b>BLACK</b> relate to Mack 200 series carriers																																				

CHASSIS
<div><b>CHASSIS</b></div> <ul style="list-style-type: none"><li>▶ Advantage 300mm x 90mm x 8mm<sup>†</sup> 156,000psi/RBM 1,940,000in lb</li> <li>▶ Advantage 300mm x 90mm x 9.5mm<sup>†</sup> 184,000psi/RBM 2,240,000in lb</li></ul> <sup>†</sup> Dependent on wheel base and axle capacity
<div><b>WHEELBASE (WB)</b></div> <ul style="list-style-type: none"><li>▶ 4,460mm (175.6") to 6,150mm (242")</li></ul>
<div><b>AFTERFRAME (RO)</b></div> <ul style="list-style-type: none"><li>▶ 1,460mm (57.5") to 2,810mm (110.6")</li> <li>▶ All chassis lengths can be specified with tapered rail ends</li></ul>
<div><b>CAB SUPPORT</b></div> <ul style="list-style-type: none"><li>▶ Front: Two metalistic pivot mounts</li> <li>▶ Rear: Air isolation with dual cabin shock absorbers</li> <li>▶ Fully suspended cab</li> <li>▶ Rear panard rod (standard)</li></ul>
<div><b>BULLBAR/BUMPER/FUPS</b></div> <ul style="list-style-type: none"><li>▶ Light weight alloy bumper (standard)</li> <li>▶ Polished alloy bullbar (optional)</li> <li>▶ Bumper and bullbar Front Underrun Protection (optional)</li> <li>▶ Air: Service and emergency with blanking plugs</li> <li>▶ Temporary transit bar (optional)</li></ul>
<div><b>AIR TANK</b></div> <ul style="list-style-type: none"><li>▶ 1 x steel tank mounted parallel to frame</li> <li>▶ Manual drain cord</li></ul>
<div><b>FUEL TANKS</b></div> <ul style="list-style-type: none"><li>▶ 26" round polished alloy tanks (Refer Wheelbase Chart)</li> <li>▶ Large capacity polished D-shaped tanks (optional) AdBlue Tank, kerbside (LHS) location <ul style="list-style-type: none"><li>▶ 125 litre stainless steel 26" round (standard)</li> <li>▶ 150 litre stainless steel 26" round (optional)</li> <li>▶ 150 litre stainless steel D-shaped (optional)</li> <li>▶ 200 litre stainless steel D-shaped (optional)</li></ul></li></ul>
<div><b>REMOTE BREATHERS</b></div> <ul style="list-style-type: none"><li>▶ Transmission, fuel and axle remote breather kit (optional)</li></ul>
<div><b>CHASSIS ACCESS STEP</b></div> <ul style="list-style-type: none"><li>▶ Staired and perforated 2 step design (optional on tractors)</li></ul>
<div><b>BATTERIES</b></div> <ul style="list-style-type: none"><li>▶ 12volt Bulldog batteries, high capacity (620 CCA)</li> <li>▶ LH and RH frame mounted with black battery box cover (standard)</li> <li>▶ Polished aluminium battery box cover (optional)</li> <li>▶ Batteries mounted in sleeper if fitted</li></ul>
<div><b>TRAILER CONNECTIONS</b></div> <ul style="list-style-type: none"><li>▶ Tractor connections back of cab (standard)</li> <li>▶ Rigid to rear of frame (standard)</li> <li>▶ Back of cab and rear of frame (optional)</li> <li>▶ Air: Service and emergency with blanking plugs</li> <li>▶ Electrical: 12volt 7-pin female base with HD 5mm² cabling</li></ul>
<div><b>ELECTRICAL</b></div> <ul style="list-style-type: none"><li>▶ Chassis harness with protective conduit</li> <li>▶ Electrical prep kit, Body Builder chassis connections (optional)</li></ul>

CAB
<div><b>SHELL</b></div> <ul style="list-style-type: none"><li>▶ Fusion Cab, ECE29 (cab crash test) compliant</li> <li>▶ Two piece windscreen (standard)</li> <li>▶ One piece windscreen (optional)</li></ul>
<div><b>SLEEPER OPTIONS</b></div> <ul style="list-style-type: none"><li>▶ 710mm (28") Super Cab with rear cabin extension</li> <li>▶ 1,015mm (40") Mid-rise premium sleeper – 4 door</li> <li>▶ 1,170mm (46") Mid-rise premium sleeper – 4 door</li> <li>▶ 1,170mm (46") High-rise premium sleeper – 4 door</li> <li>▶ 1,320mm (52") Mid-rise premium sleeper – 4 door</li> <li>▶ 1,320mm (52") High-rise premium sleeper – 4 door</li> <li>▶ All sleepers have 4 access doors and vertical cab extenders</li></ul>
<div><b>CAB INTERIOR</b></div> <ul style="list-style-type: none"><li>▶ Grey roof trim with 3 overhead storage pockets and 4 cabin lamps, complimentary Diamond Plate door trims (standard)</li> <li>▶ Slate grey pleated roof trim with overhead console and matching door trims – includes sleeper trim (optional)</li> <li>▶ Burgundy pleated roof trim with overhead console and matching door trims – includes sleeper trim (optional)</li> <li>▶ Rear wall and 2 door storage pockets</li> <li>▶ Dash: Premium wood-grain finish with integrated cup holders</li> <li>▶ Central locking (standard)</li> <li>▶ Power windows (standard)</li> <li>▶ Insulation: internal heat/noise rejection lining (standard)</li> <li>▶ Floor: Black rubber mat (standard)</li></ul>
<div><b>SEATS</b></div> <ul style="list-style-type: none"><li>▶ Driver: ISRI 'Big-Boy' air-ride (standard): Cloth trim, upper, side and lower lumbar support with fore/aft seat cushion adjustment</li> <li>▶ Driver: ISRI 'Big-Boy' air-ride Premium (optional): 'MACK' embossed cloth trim, LH arm rest, upper, side and lower lumbar support with oscillating base and fore/aft seat cushion adjustment</li> <li>▶ Passenger: ISRI fixed cushion (standard)</li> <li>▶ Passenger: ISRI luxury air ride seat with upper and lower lumbar support, and fore/aft seat cushion adjustment (optional)</li></ul>
<div><b>STEERING WHEEL</b></div> <ul style="list-style-type: none"><li>▶ Bulldog soft touch rubber grip 457mm (18") diameter (standard)</li> <li>▶ Elite leather grip steering wheel (optional)</li> <li>▶ Adjustable tilt and telescopic steering column</li></ul>
<div><b>INSTRUMENTS &amp; STANDARD GAUGES</b></div> <ul style="list-style-type: none"><li>▶ Driver information display – Co-Pilot</li> <li>▶ Speedometer/odometer (electronic)</li> <li>▶ Tachometer/hourmeter (electronic)</li> <li>▶ Voltmeter, engine hours, distance, trip recording</li> <li>▶ Engine coolant temperature, fuel/urea level</li> <li>▶ Primary and secondary air pressure</li> <li>▶ Oil pressure and oil temperature</li></ul>
<div><b>FULL GAUGE PACKAGE INCLUDES</b></div> <ul style="list-style-type: none"><li>▶ Manifold pressure, transmission temperature, exhaust temperature, brake application pressure, front and rear drive axle temperature</li></ul>
<div><b>WINDSCREEN WIPERS</b></div> <ul style="list-style-type: none"><li>▶ Electronic variable-speed, intermittent wipers with washer</li> <li>▶ Reservoir mounted under bonnet</li></ul>
<div><b>AUDIO SYSTEM</b></div> <ul style="list-style-type: none"><li>▶ Base Radio/CD player 4 x 20watt (standard)</li> <li>▶ Premium Radio/CD player 4 x 35watt including hands free (opt)</li> <li>▶ iPod connector and USB connector (optional)</li></ul>
PAINT & ACCESSORIES
<div><b>PAINT TYPE AND COLOUR</b></div> <ul style="list-style-type: none"><li>▶ Cab/sleeper: Single non-metallic cab colour</li> <li>▶ PPG – Mack White and Black</li> <li>▶ Chassis: Single non-metallic chassis colour</li> <li>▶ Alternative metallic and non-metallic colours (NSV only)</li> <li>▶ Epoxy Mine specification primer (NSV only)</li></ul>

<div><b>ACCESSORIES</b></div> <ul style="list-style-type: none"><li>▶ Many factory fitted accessories which are not listed, are also available</li> <li>▶ All customers are encouraged to see their Authorised Dealer for full details</li></ul>
--

<div><b>COMMUNICATIONS</b></div> <ul style="list-style-type: none"><li>▶ GME TX835 CB radio (optional)</li> <li>▶ GME TX4400 UHF radio (optional) NSV with <i>m</i>DRIVE</li></ul>
<div><b>CLIMATE CONTROL</b></div> <ul style="list-style-type: none"><li>▶ HVAC integral cab air conditioner/heater</li> <li>▶ Electronic controls</li> <li>▶ Replaceable dust intrusion filter</li></ul>
<div><b>COURTESY LAMPS</b></div> <ul style="list-style-type: none"><li>▶ Drivers/Passengers door entry lighting</li></ul>
<div><b>SAFETY &amp; WARNING</b></div> <ul style="list-style-type: none"><li>▶ Set of 3 safety warning triangles (optional)</li> <li>▶ Door mounted emergency procedure guide (optional)</li> <li>▶ Emergency eye wash bottle (optional)</li> <li>▶ 2.5kg in cab mounted fire extinguisher (optional)</li> <li>▶ 9kg on frame mounted fire extinguisher (optional)</li></ul>

<div><b>TYRE EQUIPMENT</b></div> <ul style="list-style-type: none"><li>▶ 20 tonne bottle jack (optional)</li> <li>▶ Wheel lug wrench kit (standard)</li></ul>
---

<div><b>CAB EXTERIOR</b></div> <ul style="list-style-type: none"><li>▶ Fibreglass bonnet and polyfibre fenders with splash aprons</li> <li>▶ Bonnet tilts forward 75° with spring assist</li> <li>▶ Chrome grille surround and side air intakes (standard)</li> <li>▶ Polished stainless steel cab skirts and air intake tubes (standard)</li> <li>▶ Black nylon bonnet hold down straps (standard)</li> <li>▶ Bright finish bonnet hold down straps (optional)</li> <li>▶ Stainless bug screen integrated with grille (standard)</li> <li>▶ Painted external sunvisor (standard)</li> <li>▶ Stainless steel exterior sunvisor (optional)</li></ul>
---

<div><b>HEADLAMPS</b></div> <ul style="list-style-type: none"><li>▶ Hella integral light/indicator unit with polycarbonate protective moulding</li></ul>
--

<div><b>MARKER &amp; TAIL LAMPS</b></div> <ul style="list-style-type: none"><li>▶ 5 roof-mounted amber lights and 3 in 1 tail lamp (standard)</li> <li>▶ LED roof clearance and tail lamps (optional)</li></ul>
---

<div><b>REVERSING ALARM</b></div> <ul style="list-style-type: none"><li>▶ Chassis mounted back up alarm (optional)</li></ul>
--

<div><b>REVOLVING ROOF BEACON</b></div> <ul style="list-style-type: none"><li>▶ Single amber revolving roof beacon (optional)</li> <li>▶ Double amber revolving roof beacons (optional)</li> <li>▶ Double amber revolving beacons air intake mounted (optional)</li></ul>
---

<div><b>HOOK UP LAMP</b></div> <ul style="list-style-type: none"><li>▶ Rear of cab mounted hook up lamp (optional)</li></ul>
--

<div><b>HORNS</b></div> <ul style="list-style-type: none"><li>▶ 2 x roof mounted, air horn trumpets</li> <li>▶ 2 x under bonnet mounted, electric</li></ul>
---

<div><b>MIRRORS</b></div> <ul style="list-style-type: none"><li>▶ Heated 'West Coast' mirrors with stainless steel arms (standard)</li> <li>▶ LH and RH power mirrors (optional)</li> <li>▶ LH and RH 7" spotter mirrors (standard)</li> <li>▶ LH down mirror (optional)</li></ul>
--

<div><b>WINDSCREEN STONE GUARD</b></div> <ul style="list-style-type: none"><li>▶ Matt black mesh windscreen stone guard (optional)</li></ul>
--